

WP363G monocrystalline silicon single flange remote transmitter

Apply to the measurement of liquid level and pressure

Adopt HART fieldbus technology, which can provide more field information to improve the performance of the factories.

Product instruction

WP363G monocrystalline silicon single flange remote transmitter

- Adopt MEMS monocrystal silicon high-precision pressure sensor
- With high response speed and stability
- Measurement accuracy 0.25%FS
- The max. range ratio can reach to 10:1
- Adopt double overload protection technology
- Provide standard HART bus communication mode
- Sophisticated self-diagnosis and telecommunication function
- Highlighted LCD with backlight
- Local display screen which can rotate by 360°
- Convenient local zero clearing function
- Convenient local zero point, extreme point setting and calibration function
- Convenient local current loop calibration function

Advanced manufacturing technique

The most reliable quality experience

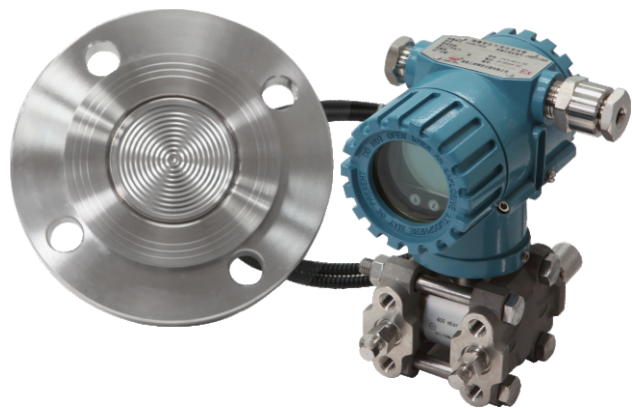

Product Introduction

Sensor membrane head

While working, the isolation diaphragms on the high/low-pressure sides and the filling liquids will transmit the process pressure to the membrane head of sensor and then converted into the corresponding current, voltage or digital HART® (high-speed addressable remote transmitter data highway) output signal.

WP363 series sensor can conduct temperature measurement to compensate the temperature effects.

In the characterization process of factory, all the sensors have gone through the pressure and temperature cycle test within the whole working range. The correction factors will be generated from these obtained data. Then the coefficients will be stored in the memory of intelligent board so as to ensure that the signal correction can be conducted precisely during the operational process of transmitter.

Electronic circuit board

The electronic board adopts high-performance integrated circuit and surface packaging technology. This board will correct the input signal of sensor and then conduct linear treatment. The output part of electronic board module will convert the digital signal into analog output and conduct communication with the manipulator.

The liquid crystal header can display the pressure value, current value or the percentage of range.

Data storage

The configuration data will be stored in the permanent EPROM storage of transmitter electronic board module. After the transmitter is power down, the data will be stored permanently. So after power on, the transmitter can work immediately.

Digital/analog conversion and signal transmission

The process variable is stored in the form of digital data, which can be corrected accurately and conducted the conversion of engineering units. After correcting the signal, the data will be converted into analog output signal. HART manipulator can directly access to the reading of sensor in the way of data signal so as to get higher accuracy without digital/analog conversion.

Communication format

WP363 series transmitter adopts HART protocol to conduct communication. This protocol adopts industrial standard Bell202 frequency shift keying (FSK) technology. The telecommunication can be conducted by overlaying high-frequency signal on the analog output. By using this technology, the communication and output can be realized simultaneously without influencing the integrity of loop. WP363 series transmitter can communicate with the host machine, which uses HART protocol.

Software function

The users of HART protocol can easily use the functions of WP363 series, such as menu configuration, test and specific settings.

Configuration

By using HART manipulator, users can conveniently conduct current regulation, parameter configuration, HART information, two-point fine tuning and graphical monitoring on WP363 series menu, including:

- Zero and extreme point setting
- Engineering units selection
- Linear or square root output
- Damping time
- Display mode
- Display accuracy

HART information can input the informational data into the transmitter to identify and physically describe the transmitter, including:

- Date
- Station identification: within 8 characters
- Station description: within 16 characters
- Information: within 32 characters

Test

When the system goes wrong, if the operator confirms that the loop has faults, can let the transmitter provide specific output for loop tests.

Specific settings

In the initialization phase of transmitter and while maintaining the digital electronic board, specific settings should be conducted. It allows to conduct fine tuning on the sensor and analog output to accord with the pressure standard of the factory.

Options

Liquid crystal header

Digital header, 2-line 5-digit liquid crystal display

- Directly display the digital data, with higher accuracy
- Display the pressure, current or range percentage according to the requirements of users
- Can rotate by 360°, which is easy to install

Transient voltage resistance protection

- Integrative transient voltage resistance protection terminal
- Electromagnetic compatibility accords with the national standard:

IEC6100-4-2 Electrostatic discharge immunity test IIIB

IEC6100-4-4 Electrical fast transient pulse clusters anti-interference test IIIB

IEC6100-4-5 Surge (shock) immunity test IIIB

Specification

Performance index

The overall performance is the composition error based on the reference accuracy, ambient temperature effects and range static-pressure effects.

Accuracy index

±0.025%FS (conventional)

Concrete performance index

(Zero-base range, reference conditions, silicone oil filling liquid, 316 stainless steel isolation diaphragm, 4~20mA analog output, the digital fine-tuning value is equal to the set point value of range.)

Accuracy

(The reference accuracy includes hysteresis, linear, setting ability and repeatability, which are based on terminal.)

±0.25%range

If the range is less than X

± [0.3+0.075 $\frac{X}{\text{range}}$]%

X value:

Diaphragm capsule	XKPa
V	100
A	300
G	1000

Damping time constant

The total damping time constant is equal to the sum of the damping time constants of amplifier unit and diaphragm capsule. The damping time constant of amplifier unit is adjustable within the range of 0~100s.

Diaphragm capsule (silicone oil)

Time constant (s) (The time constant can be set according to the actual situation of field and is recommended 1S)

Influence of installation position

The changing of installation position, which is parallel to the surface of diaphragm, will not cause the effect of null shift. If the change between the installation position and the surface of diaphragm do not exceed 90°, the null shift within 0.4KPa can be corrected by zero setting without influencing the range.

Influence of power supply

Less than ±0.005% range/v

Functional parameter

The limit value of range and sensor

Table 1: Range of WP363L transmitter and limit value of sensor

Range	Min. range	Limit value of range and sensor	
	WP363G type	Upper limit of range (URL)	Lower limit of range (LRL)
M	10KPa	40KPa	-40KPa
H	50KPa	250KPa	-250Pa
V	100KPa	1MPa	-1MPa
A	300KPa	3MPa	-3MPa
G	1MPa	10MPa	-10MPa

Zero point and range adjustment requirements

- The zero point and range can be adjusted arbitrarily within the range limit value indicated in Table 1.
- The range should be larger than or equal to the min. range indicated in Table 1.

Applications

Measurement of liquid, gas and steam

Output

Two-wire 4~20mA, linear output or square root output is selectable for users. Digital process variable overlays on the 4-20mA signal, which can be applied to the host machines according with HART protocol.

Power supply

Need external power supply. While standard transmitter (4-20mA) has no load, work at 14.5-45V DC.

Loop load limit

The max. loop resistance is decided by the voltage of external power supply, the relations are as follows:

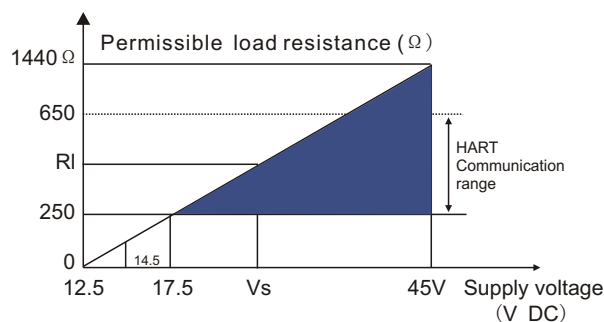

Supply voltage - load characteristic relation scheme

Note: The supply voltage range of transmitter with backlight display is 14.5~45V

The supply voltage range of intrinsic-safety series transmitter is 14.5~28V.

The working voltage while HART communication should be larger than 17.5V.

Limit of static pressure and max. overpressure

For WP363G type, the limit value is from 0psia to flange rated value or the smaller one in the rated pressure values of sensor.

Table 2. Pressure rated value of WP363G type flange

Standard	Type	Rated value of carbon steel	Rated value of stainless steel
ANSI/ASME	Class150	285psig	275psig
ANSI/ASME	Class300	740psig	720psig
ANSI/ASME	Class600	1480psig	1440psig
<i>For the measured value under 38°C, the rated value will decrease with the increasing of temperature.</i>			
DIN	PN 10-40	40bar	40bar
DIN	PN 10/16	16bar	16bar
DIN	PN 25/40	40bar	40bar
<i>Under 120°C, the rated value will decrease with the increasing of temperature.</i>			

Fault mode

Output code

While discovering the faults of sensor or microprocessor by self diagnosis, the transmitter will output one high or low alarm signal to prompt the users. The alarm output value is subject to the factory configuration mode of transmitter:

- Linear output: $3.8 < I < 20.8$
- C4: I=20.8mA high fault
- CN: I=3.8mA low fault

Temperature limit

Environment

-20°C ~ +70°C

Storage

-46°C ~ 110°C

With header: -40°C ~ 85°C

Process

Less than or equal to atmosphere, see the following table:

Table 3. Limit of WP363G process temperature

DC silicone oil 200	-45 to 205°C
DC silicone oil 704	-10 to 315°C
Fluorocarbon oil	-18 to 204°C

Humidity limit

0-100% relative humidity

Starting time

Reach to the performance index within 2s after the transmitter is power up.

Mechanical performance index

Electrical interface

ANSI (American-Standard) NPT1/2(F) internal thread

ISO (Chinese standard) M20×1.5 internal thread

Process interface

High-pressure side: flange size (execute national and chemical industry standard)

NP series: DN25 DN40 DN50 DN80 DN100

PN2.5 PN6 PN10 PN16 PN25 PN40

Class series: 1 inch, 1½ inches, 2inches, 3inches,

4 inches, 150lb、300lb

Low-pressure side: 1/4-18NPT taper pipe internal thread

T-shaped interface: M20×1.5 external thread and back welding connecting pipe

Waist-shaped interface: 1/2-14NPT taper pipe internal thread, 1/2-14NPT pressure-leading transition head and back welding connecting pipe

Process liquid-contacting piece

Process isolation diaphragm: 316L stainless steel, hastelloy C (Plug-in cartridge doesn't have this option.), Ta (Plug-in cartridge doesn't have this option.).

Drain/vent valve

316 stainless steel

Process flange and interface

316 stainless steel

WP363G type process liquid-contacting piece

Flange type process interface (the high-pressure side of transmitter)

Process diaphragm, including process gasket contacting surface

316L stainless steel, hastelloy C or Ta

Extension part

316 stainless steel

Mounting flange

Carbon steel galvanization or stainless steel

Process connection on the low-pressure side (the low-pressure side of transmitter)

Isolation diaphragm

316L stainless steel

Flange and interface on the low-pressure side

316 stainless steel

Non-liquid-contacting piece

Shell

Aluminium die casting IP65

Coating

Spraying plastics

Meter cap O-ring

Nitrile rubber

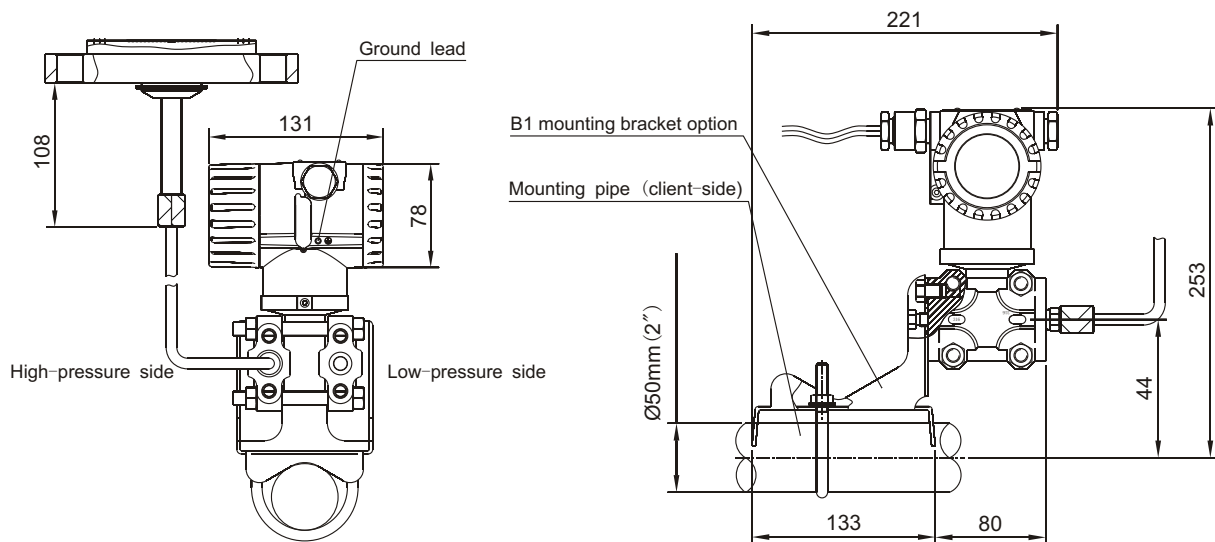

Outside drawing of single-flange installation

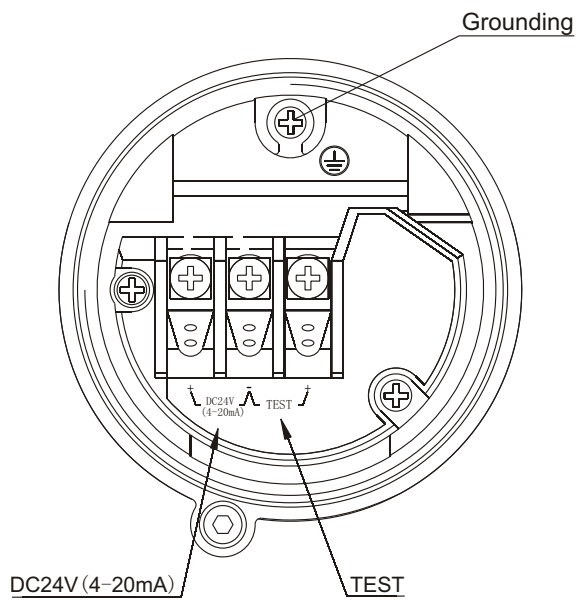

Connecting terminal	
DC24V(4~20mA) ⁺ ₋	Power supply and output end
TEST ⁺ ₋	Connect to the testing terminal of ampere meter (impedance should be less than 10 Ω)
\perp	Ground terminal

Wiring diagram of terminal side

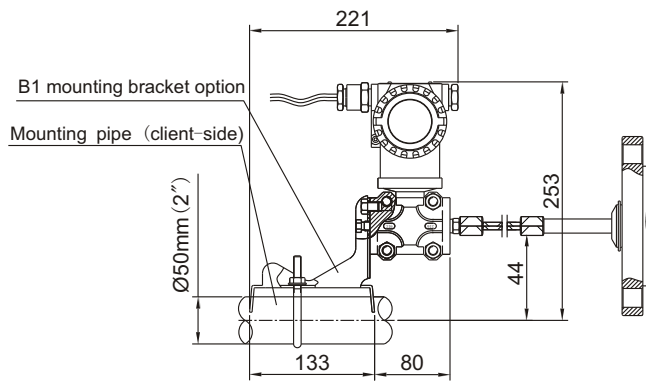

Subassembly of B1 mounting bracket

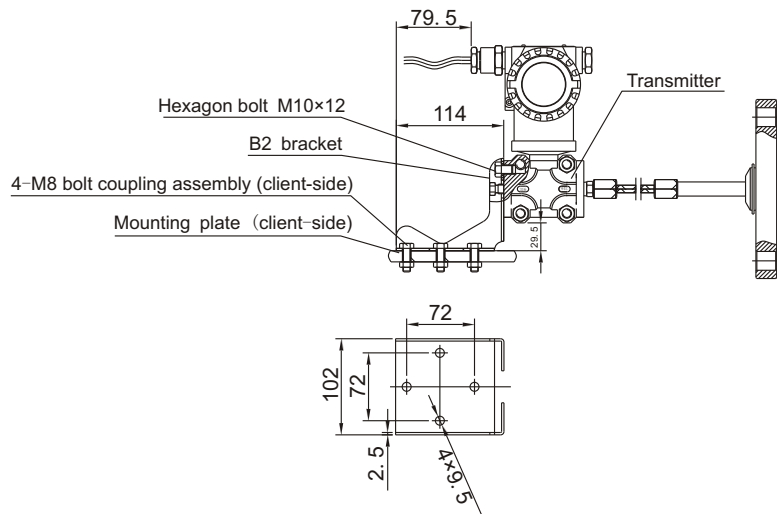

Subassembly of B2 mounting bracket

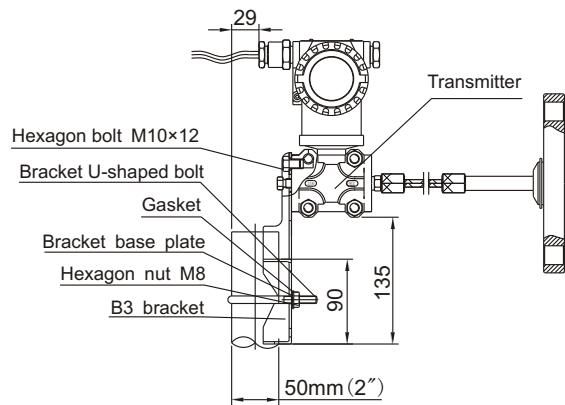

Subassembly of B3 mounting bracket

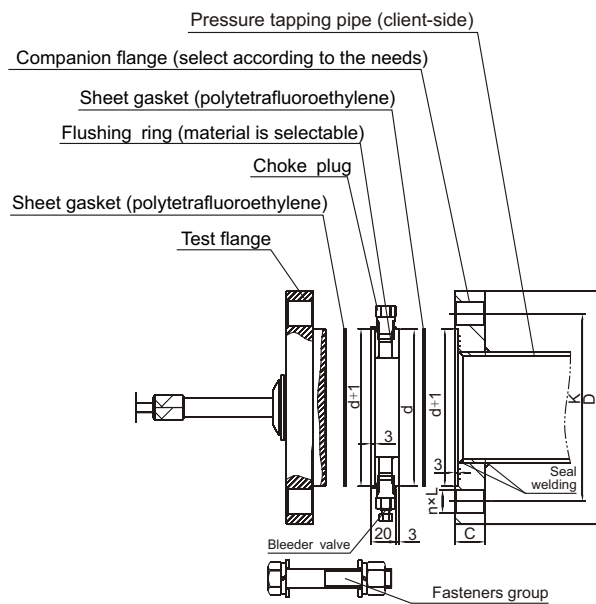

F1/F2 flushing ring

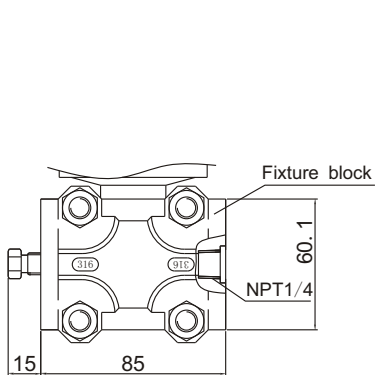

Process connecting type - leading pressure optional figure (P)
- 1/4-18NPT taper pipe female thread

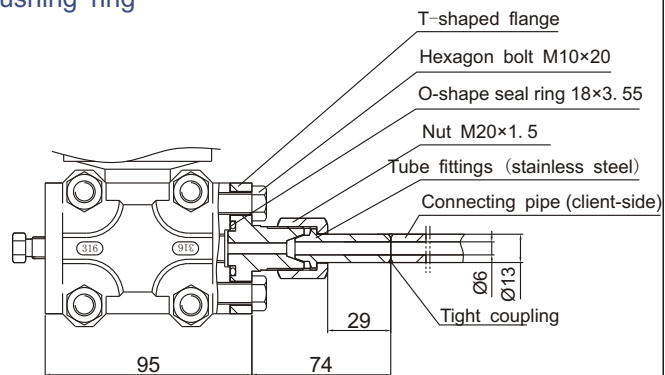

Process connecting type - leading pressure optional figure (J)
- T-shaped interface, with connecting pipe interface on the back

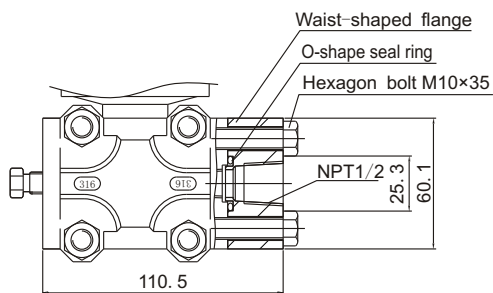

Process connecting type - leading pressure optional figure (N)
- Waist-shaped interface

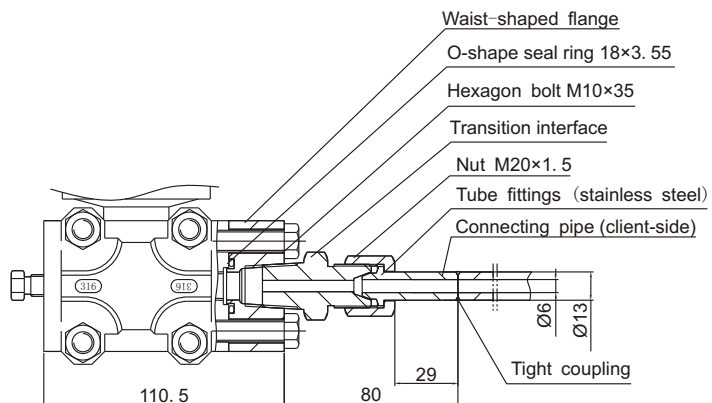

Process connecting type - leading pressure optional figure
- NPT1/2-14 pressure-leading transition head,
with connecting pipe interface on the back

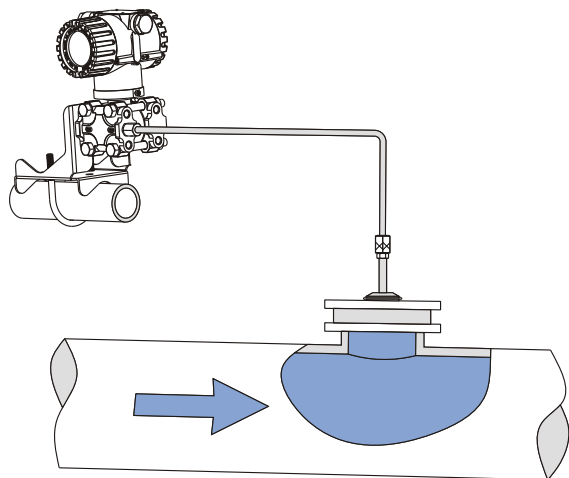

The flange installation mode of pipeline pressure

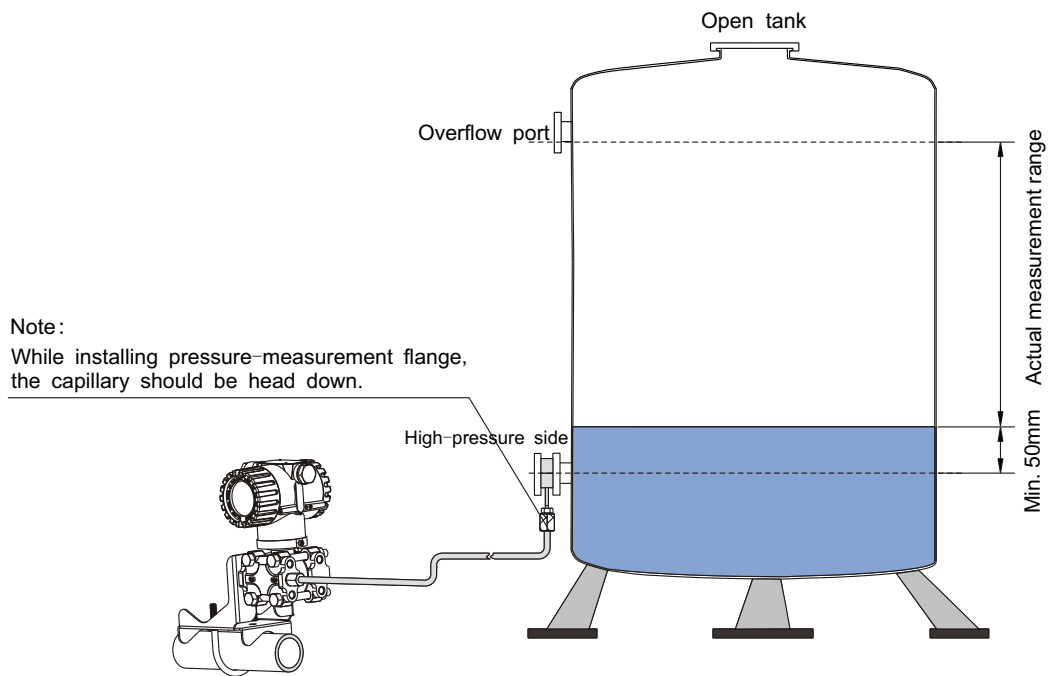

Flange installation mode of open tank liquid level

Field installation figure for single remote-transmission diaphragm system

Table 5. WP363G monocrystalline silicon single flange remote transmitter

Model	Transmitter type		
WP363G-	Monocrystalline silicon single flange remote transmitter		
Code	Measurement range of pressure		
M	0-10~40KPa		
H	0-50~250KPa		
V	0-0.1~1MPa		
A	0-0.3~3MPa		
G	0-1~10MPa		
Code	Flange standard		
P	Chemical industry standard HG/T20592-2009 (steel tube flange PN series - RF raised face flange) (adduce European system)		
C	Chemical industry standard HG/T20615-2009 (steel tube flange Class series - RF raised face flange) (adduce American system)		
Y	Other flange standard		
Code	Type of sealing element		
P	Flat trpe		
R	Flange type		
E	Plug-in cartridge type (not offer DN25, DN40, 1 inch and 1 1/2 inches)		
T	Thread type		
Code	Nominal aperture of flange		
	PN series (Eropean system)	Class series (American system)	Thread type spec.
1	DN25	1 inch	NPT1/2
2	DN40	1½ inches	NPT1/4
3	DN50	2 inches	NPT3/8
4	DN80	3 inches	NPT1
5	DN100	4 inches	NPT 1½ (without
Y	Special requirements	flushing hole)	
Code	Aperture pressure grade		
	PN series (Eropean system)	Class series (American system)	
1	PN2.5、PN6(bar)		
2	PN10、PN16(bar)	Class150(lb)	
3	PN25、PN40(bar)	Class300(lb)	
Y	Special requirements		
Code	Plug-in cartridge extension length		
0	0 (Without Plug-in cartridge)		
2	50mm		
4	100mm		
6	150mm		
8	200mm		
Y	Special requirements		
Code	High pressure H-terminal capillary length		
??	The length of capillary is from 1~10m, indicated by ?? (for instance: 2m:02)		
Code	Diaphragm material		
-A	316L stainless steel		
-B	Hastelloy C (Plug-in cartridge type doesn't have this option.)		
-C	Ta (Plug-in cartridge type doesn't have this option.)		
-Y	Special requirements		

Table 5 (continued). WP363G monocrystalline silicon single flange remote transmitter

Code	Process filling liquid - high-pressure side	Temperature limit	Contact temperature
D	Normal-temperature silicone oil	-45 to 205℃	-40 to 120℃
C	High-temperature silicone oil	0 to 315℃	0 to 120℃
H	Fluorocarbon oil	0 to 315℃	-18to 120℃
Code	Electrical interface		
A	NPT1/2 internal thread		
M	M20×1.5 internal thread		
Code	Options for the hazardous occasion certification		
N	Ordinary type (no anti-explosion)		
D	Flame-proof Exd II CT6		
I	Intrinsic-safety type Exia II CT6		
Code	Mounting bracket		
B3	Pipe-mounted flat bracket (2" pipe)		
B1	Pipe-mounted bent bracket (2" pipe)		
B2	Plate-mounted bent bracket		
Code	Other option		
H	The measurement accuracy is 0.1%FS		
S	The material of flange is 316 stainless steel		
G	The isolation diaphragm is gold-plated		
F	Diaphragm sticking with polytetrafluoroethylene		
T	Diaphragm coating with teflon		
Q4	Verification certificate(Contact Wide Plus)		
C4	High alarm		
CN	Low alarm (The default setting is low alarm)		
F1	Stainless steel flushing adapter ring (Plug-in cartridge type doesn't have this option.)		
P	NPT1/4 Taper internal thread (low pressure side)		
J	Connector with "T" shape: M20×1.5 external thread and rear welded pressure tube (low pressure side)		
N	Connector with "Waist" shape: NPT1/2 conical pipe thread (low pressure side)		
C	NPT1/2 primer and rear welded primer tube (low pressure side) with "Waist" connector		
Y	Special requirements		

Note: 1, When the length of capillary increased, the accuracy is reduced.

2.if needing higher precision, please contact the marketing representatives of the corporation.

3,The default flange material is 304 stainless steel